

Road State Sensor (Non-Contact)

HIGHWAY/ROAD SENSOR DATASHEET

Balaji Hydromet is a non-contact road surface state detector **Model: BHM-S-RSS1**, thanks to its remote sensing technology, it can not only avoid damage to the road, but also traffic interference during its installation. Multispectral measurement technology enables accurate detection of thickness of ice, snow, water on surface of the road. **BHM-S-RSS1** detector is ideal choice for road conditions where installation of embedded pavement sensor is inconvenient or inapplicable. Remote sensing measurement, means that there is no need to slot-cut surface or shut down the road, its installation is safe and convenient. It's almost free of maintenance and ideal choice for road meteorological systems. It can be installed on existing weather stations or on other buildings which has unobstructed view to pavement.

The **BHM-S-RSS1** detector is installed in a robust durable housing to ensure it's stable working and providing accurate data during bad weather. By providing accurate road state information, **BHM-S-RSS1** can alarm road management department to take appropriate remedial action. before weather elements has created a hazardous driving surface.

- Measure thickness of ice, snow, water on road surface
- Contactless sensing technology
- Convenient installation
- Low maintenance cost

INSTALLATION - VIEW

PROFESSIONAL LINE	SPECIFICATION
Model	BHM-S-RSS1
Measure distance(c)	2~8 meters
Measure area diameter(d)	typical 20 cm, c : d = 20 : 1
Installation angle:	30-80°
Distinguishable road state:	Dry, Moist, Wet, Snow, Ice, SLUSH
Applicable road material	Concrete and asphalt
Water range	0~2 mm (Resolution:0.01mm)
Ice range	0~2 mm (Resolution:0.01mm)
Snow range	0~2 mm (Resolution:0.01mm)
Grip level	0~0.82(Resolution:0.01)
Surface temperature	-40~70°C
Resolution	0.1°C
Accuracy	±1°C
Lens contamination compensation	Automatic
Serial Output	RS232 or RS485
Formats	unsolicited ASCII or MODBUS-RTU
Power supply	12-24 VDC
Operating temperature	-40 ~ +70°C
Protection Grade	IP65

APPLICATION - VIEW

- Bridge road
- Accident-prone areas
- Road state early alarm system
- Rain and snow-prone areas

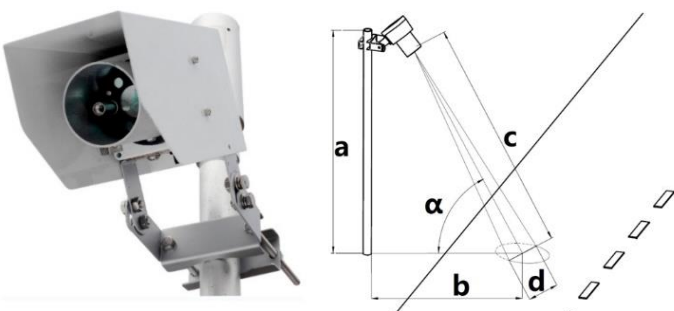

Representative